

LOC		DIST		REVISIONS			
DF	DO	TR	LYR	DESCRIPTION	DATE	OWN	APPRO
		C	REV PER	0630-320-01	5-02	CT	DM
		D	REV PER	0630-0619-02	7-03	JMK	LO

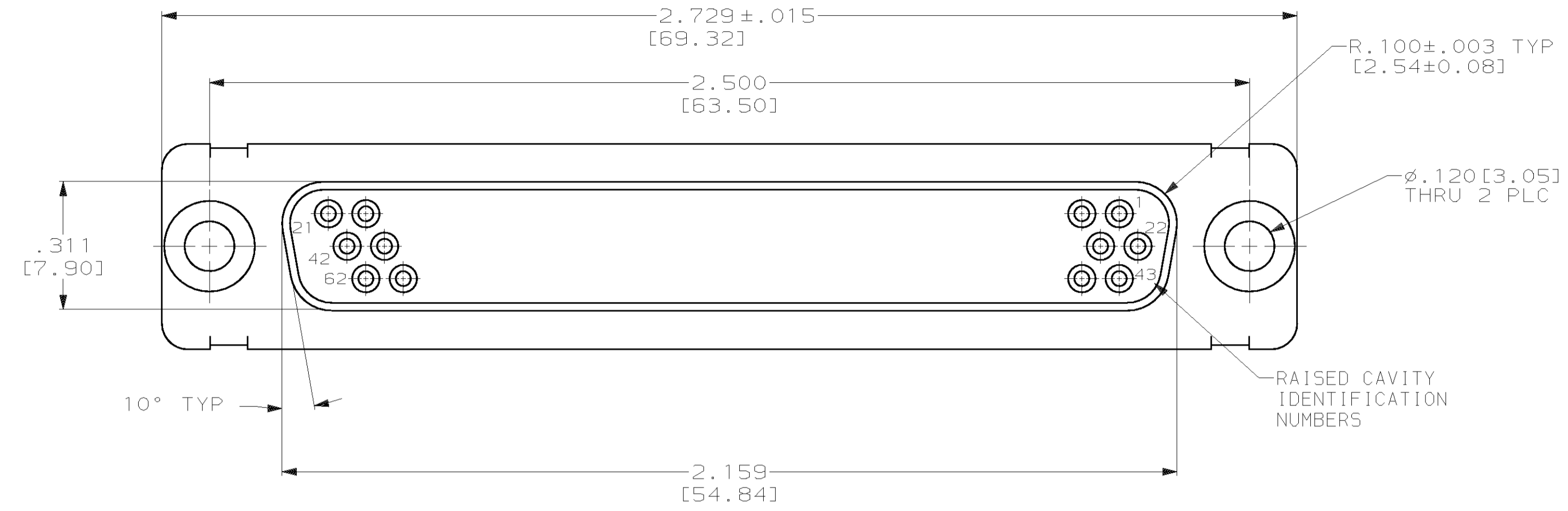

- 1. CONTACTS INCLUDED IN ASSEMBLY.
- 2. CONTACT
 BODY MATL: BERYLLIUM COPPER PER ASTM-B-197.
 BODY FINISH: PLATED GOLD, .000050 MIN THK PER MIL-G-45204 OVER NICKEL, .000050 MIN THK PER QQ-N-290.
 HOOD MATL: STAINLESS STEEL PER ASTM-A-167.
 HOOD FINISH: PASSIVATED PER ASTM-A-380
- 3. MATL: BRASS PER ASTM-B-36.
- 4. FINISH: PLATED GOLD, .000050 MIN THK PER MIL-G-45204 OVER COPPER, .000100 MIN THK PER MIL-C-14550.

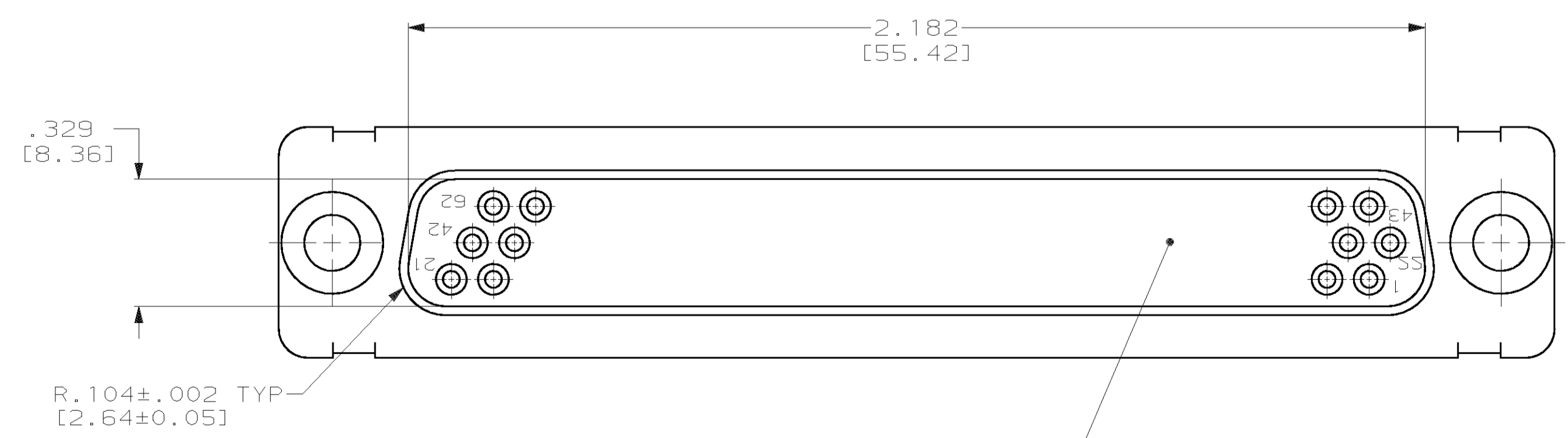
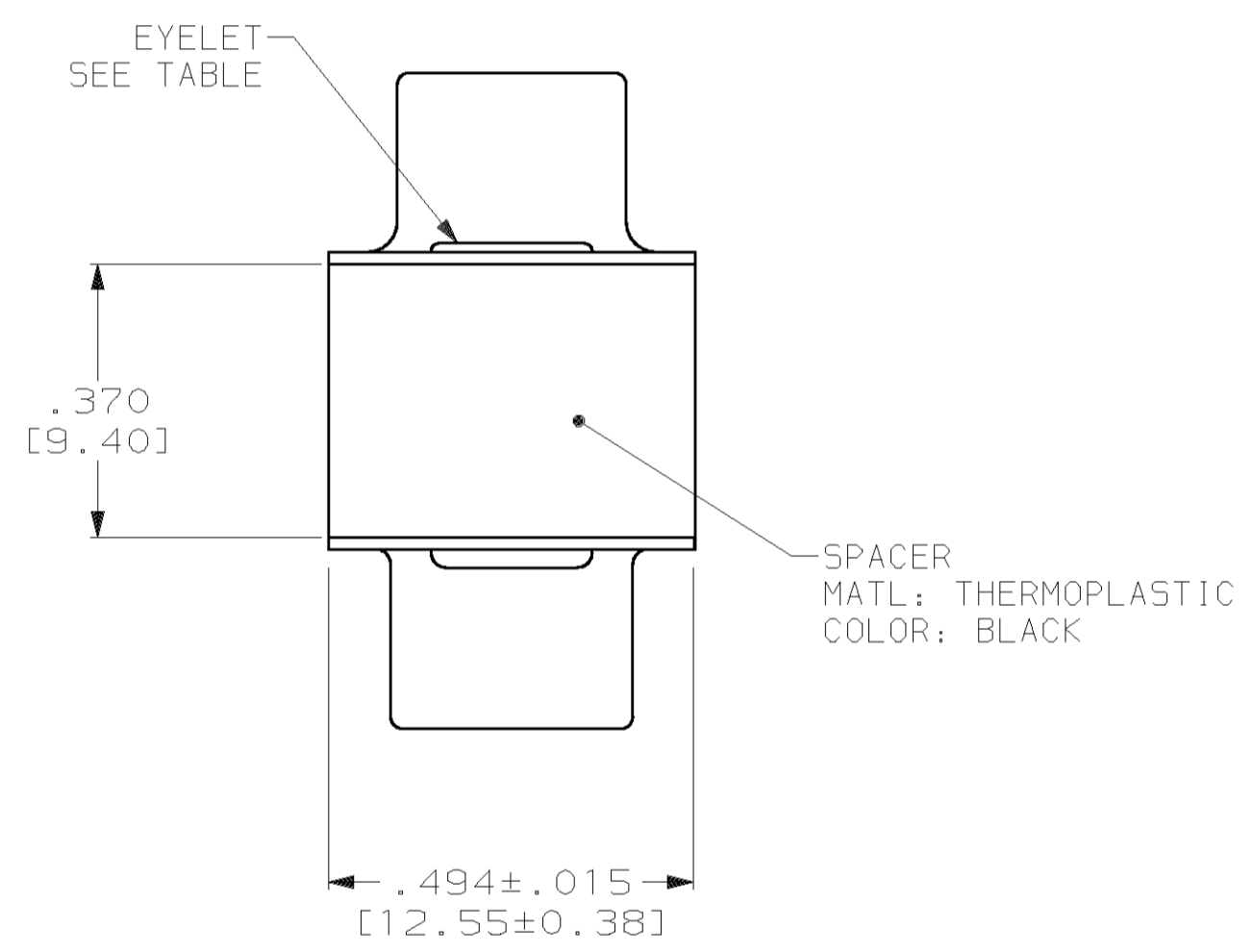
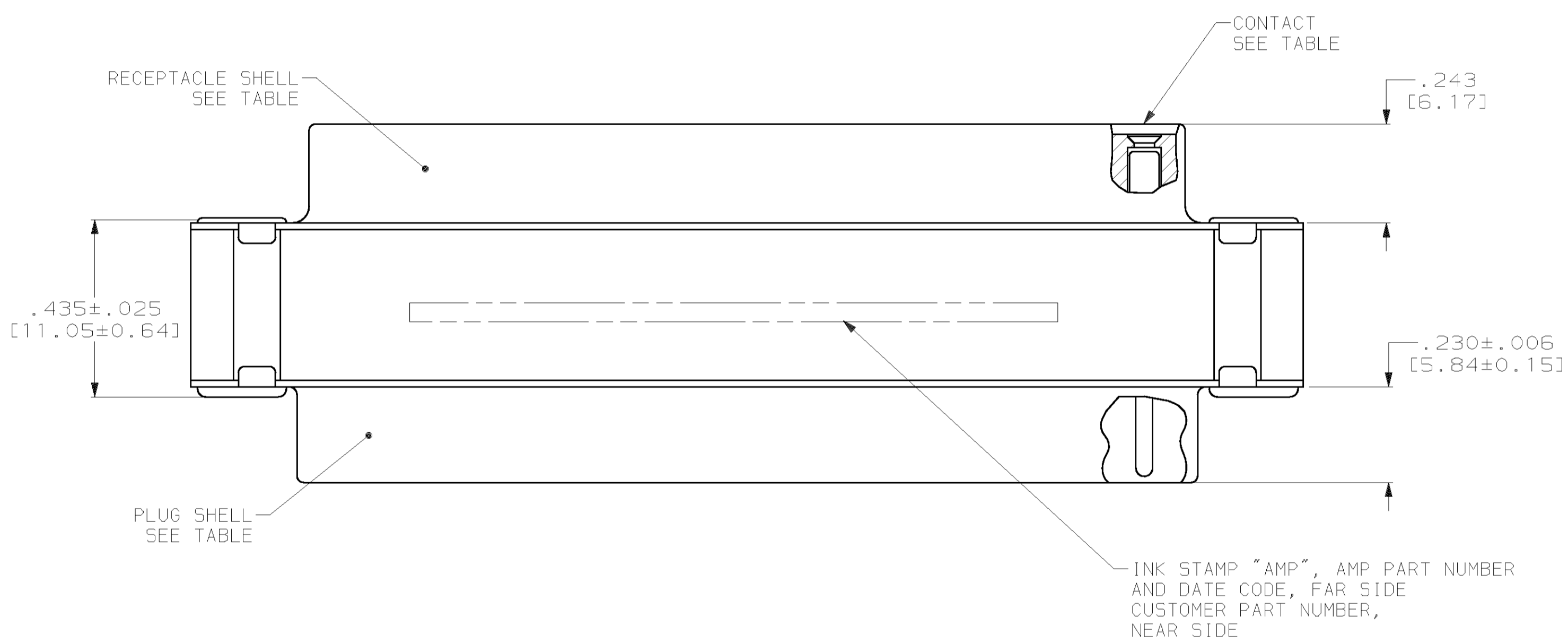

INSERT ASSEMBLY
 MATL: POLYESTER PER MIL-M-24519
 TYPE GPT-30F
 COLOR: BLUE
 OR POLYPHENYLENE SULFIDE (PPS)
 PER MIL-M24519, TYPE GST-40F
 COLOR: BLACK

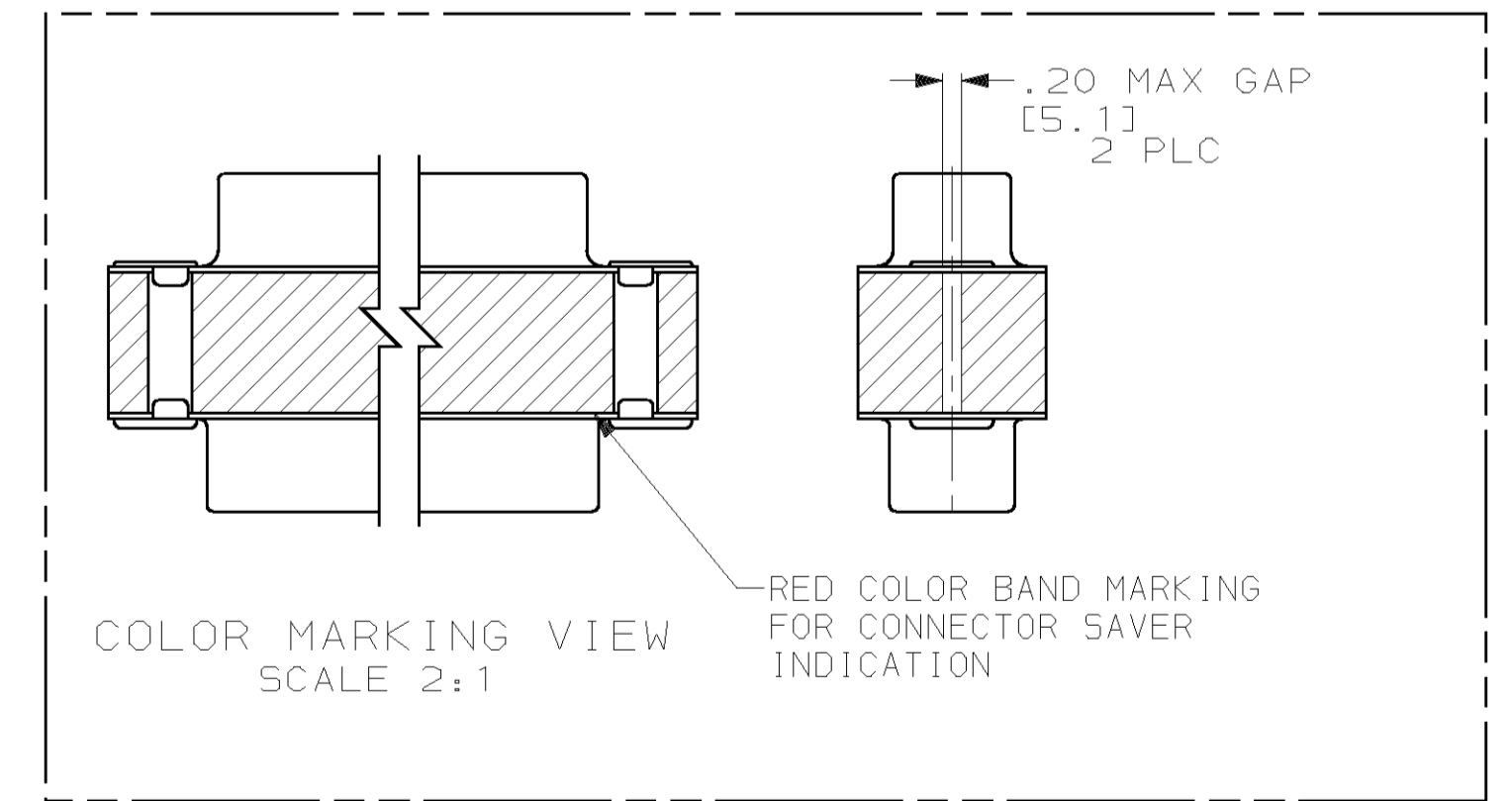

3/4	3/4	2	4U884 SOCN R10002677-0009	1218311-2
3/4	3/4	2	(1J02-009)	1218311-1
EYELET	SHELLS	CONTACT	CUSTOMER P/N	PART NO.

THIS DRAWING IS A CONTROLLED DOCUMENT.		I. THOMPSON		AMP Incorporated	
CHK: J. NORTON		20AUG98		Harrisburg, PA 17105-3608	
APPROV: J. NORTON		20AUG98		NAME: AMPLIMITE CONNECTOR SAVER	
DIMENSIONS: IN (mm)		TOLERANCES UNLESS OTHERWISE SPECIFIED:		PRODUCT SPEC	
0 PLC ±.010		1 PLC ±.010		APPLICATION SPEC	
2 PLC ±.010		3 PLC ±.005(0.13)		SIZE: A1	
4 PLC ±.010		ANGLES		CAGE CODE: 00779	
MATERIAL		FINISH		DRAWING NO: 1218311	
				RESTRICTED TO	
				CUSTOMER DRAWING	
				SCALE: 4:1	
				SHEET 1 OF 1	
				REV D	